

The StarLeaf Line of Faceting Machines

Are precision-made, versatile and compact machines at an economical price. These machines include features like tilting ring quadrants which rotate 360°, rapid indexing features, easy to change diamond tool holders and accurate centering scopes.

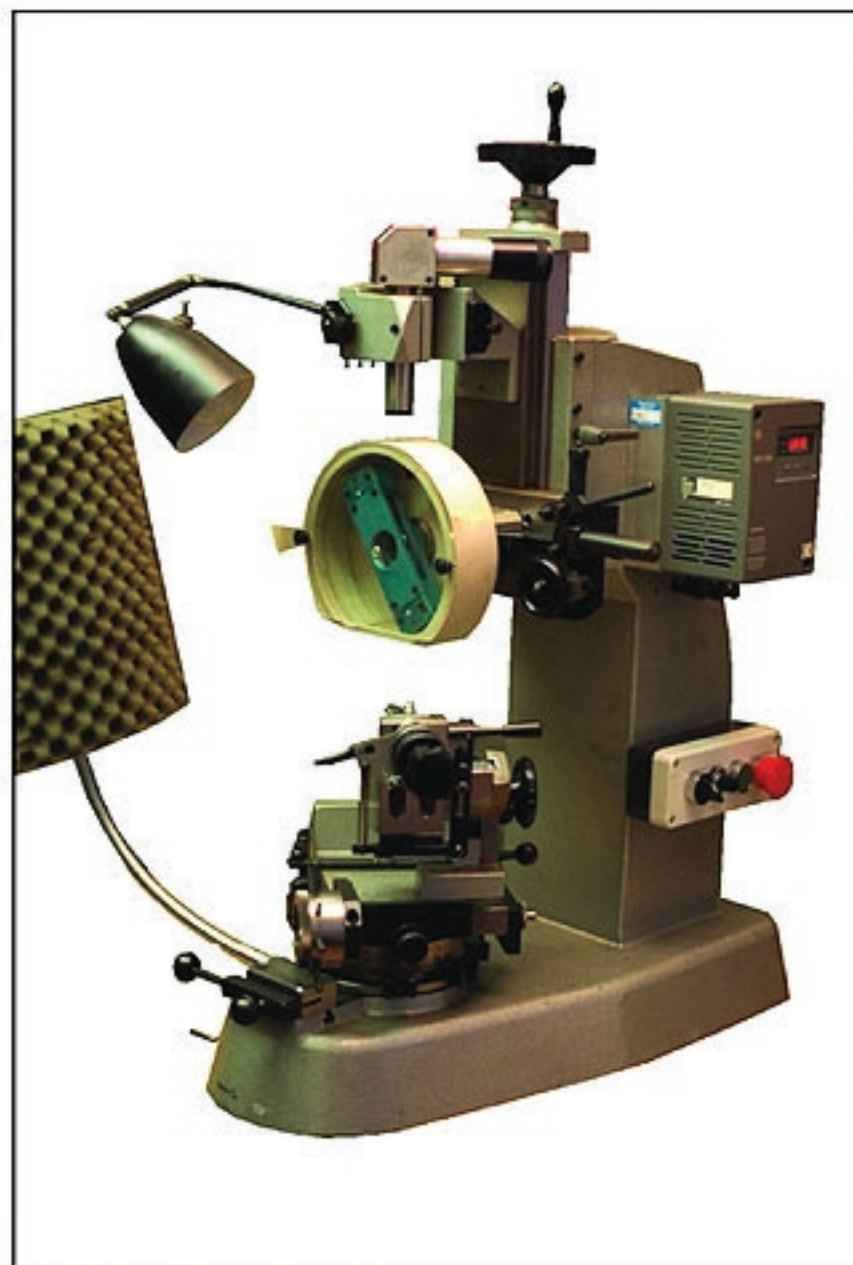
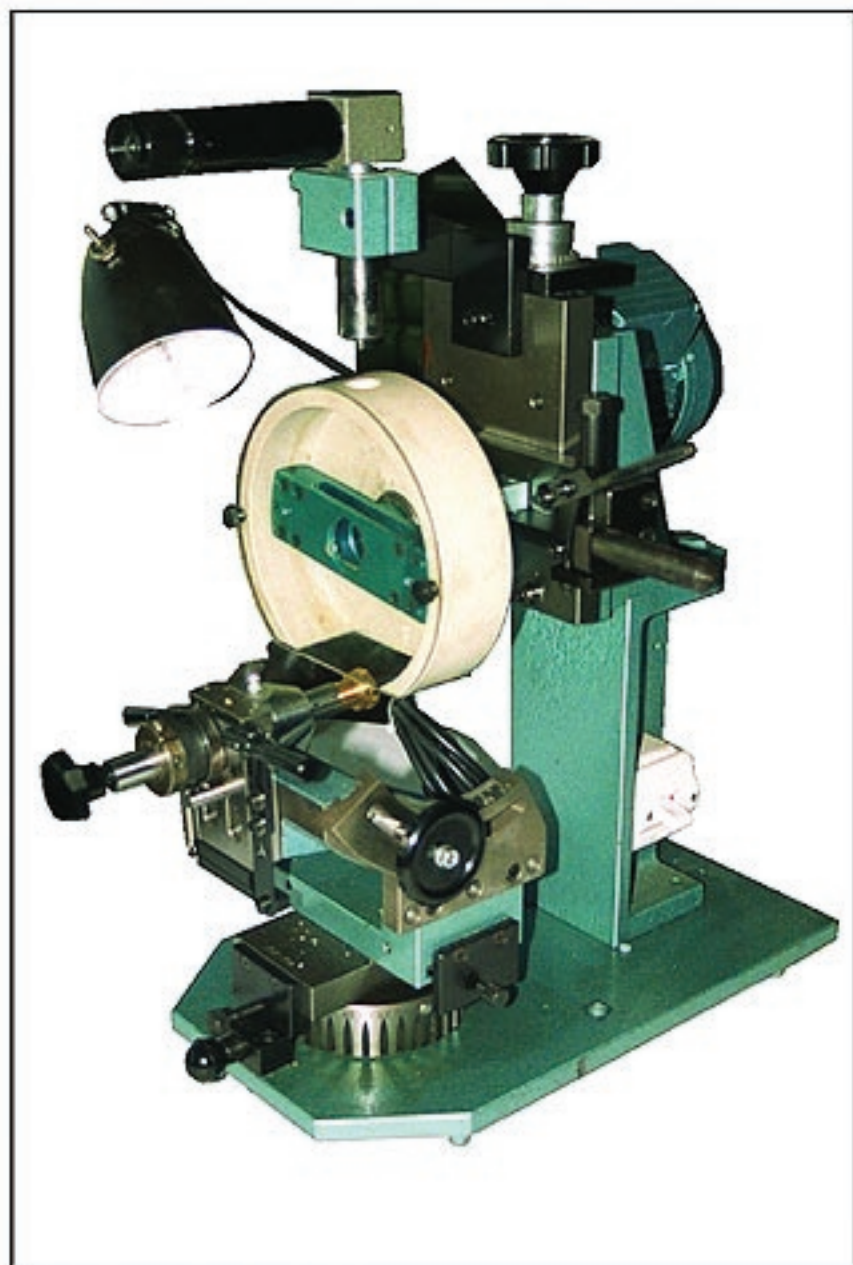

M-1 Faceting Machine

67-010

Manual operation for horizontal cutting designs. Includes a 6 tool holder head, centering scope and a set of 26 ring collets on a pegboard.

SPECIFICATIONS:

Dimensions: 16" w x 32" d x 29" h (407 x 814 x 737mm)

Energy: 1/4hp, 220V, 50/60hz, 3 phase, 7 amps

Shipping weight: 280lbs (127kg)

Order quadrant or table separately.



M-2 Faceting Machine

67-020

Manual operation for vertical cutting designs. Includes a 6 tool holder head, centering scope and a set of 26 ring collets on a pegboard.

SPECIFICATIONS:

Dimensions: 25 1/4" w x 32" d x 35 1/4" h (650 x 800 x 900mm)

Energy: 1/4hp, 220V, 50/60hz, 3 phase, 7 amps

Shipping weight: 176lbs (80kg)

Order quadrant or table separately.



Diamond Tools for Faceting

Eisinger's diamond tools for faceting are made with top quality diamonds. They are used to give long lasting bright cuts. The shapes and sizes listed are carried in stock. Other shapes and sizes are available on special order.

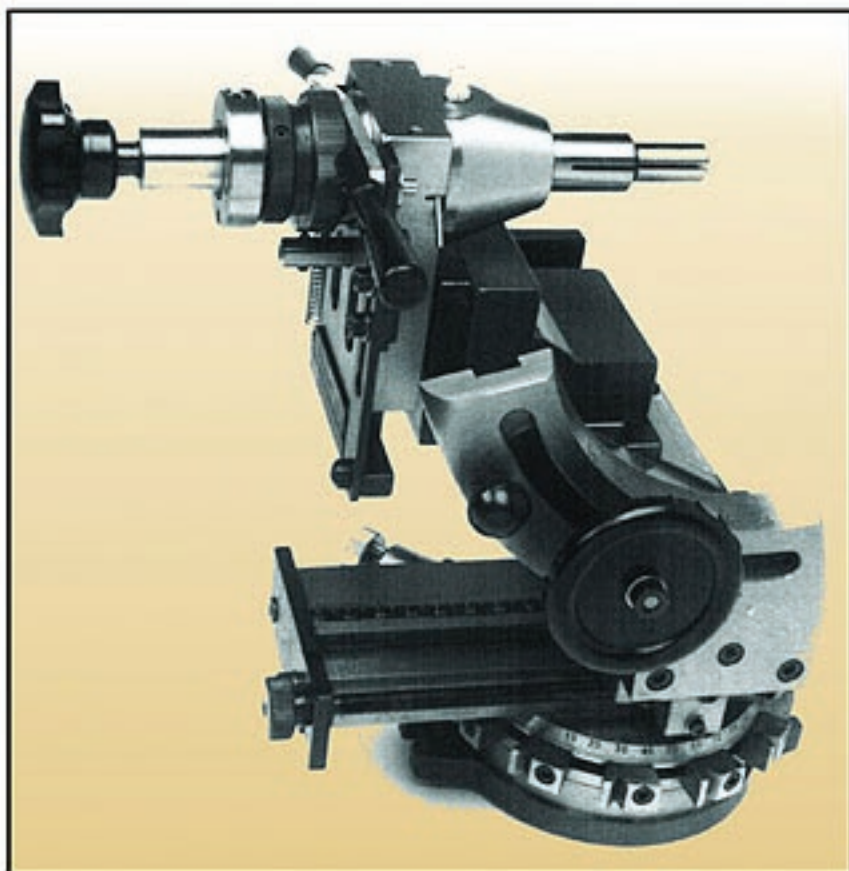

StarLeaf M11B Tilting Ring Quadrant

67-411B
 The M11B is the most flexible of all ring quadrants. It allows a full 360° rotation on its base and can tilt up to 60° from horizontal. Rapid action indexing as well as locking and opening of the collet make this the ideal quadrant.
 Shipping weight: 20lbs (9kg)

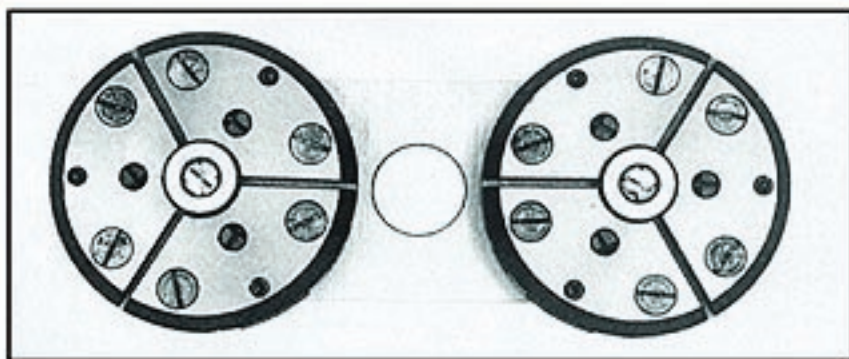

Horizontal Tool Holder

66-809*
 6 tool, 150mm. This versatile tool holder allows you to change from one diamond or carbide tool to the next without removing the tool holder or realigning the machine.
 Shipping weight: 11lbs (450g)
 *Other tool holders available.

Ring Collet Set

67-733
 Set of 26 collets, sizes 3 to 15 1/4.
 Shipping weight: 3lbs (1.5kg)



Angled Diamond Tools

Two finished edges, 3mm wide.

Angle	Order #
90°	64-002
120°	64-032
130°	64-042
140°	64-052
150°	64-062

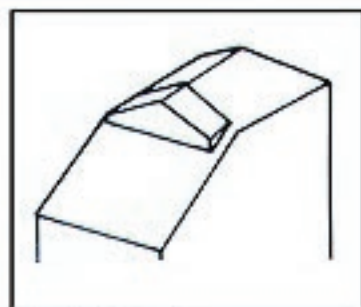

Any desired angle and width can be made to order.
 Shipping weight: 2oz (60g)

Flat Diamond Tools

Four finished edges.

Width (mm)	Order #
1/4	64-101
1	64-103
1 1/4	64-104
2	64-105
3	64-107



Any desired width can be made to order.
 Shipping weight: 2oz (60g)

Flat Carbide Tools

Tooth Spacing	Order #
no teeth	63-110
0.15mm	63-002
0.25mm	63-003
0.40mm	63-004

Shipping weight: 2oz (60g)



Short Angled Carbide Tools

No teeth.

Angle	Order #
90°	63-121
120°	63-151
150°	63-181

Shipping weight: 2oz (60g)

